

**USAGE AREAS:**

It is suitable for use in outdoor and indoor sports facilities, concerts and event areas.

**SYSTEM DEFINITION:**

New generation BALANCE-Y folding stadium seat, produced with Gas Inflation Technique, is a system that can be mounted on the ground.



**FEATURES:**

The fixed grandstand seat offers comfortable and practical use with its ergonomic design, lightweight portability, easy assembly, and durability.

**BALANCE-Y**

## TECHNICAL SPECIFICATIONS

1	The production process is carried out using the injection method with the original polypropylene copolymer raw material.
2	The seat has a rib-reinforced and double-walled structure to enhance fracture resistance under load.
3	For color stability, color pigments with the highest level of light fastness are preferred, and measures have been taken to prevent color fading and chalkiness with UV and antioxidant additives.
4	The front design of the seating area is shaped in an oval form that does not disturb the legs. The back is produced in a curved and ergonomic structure to provide comfort to the user.
5	The production involves the use of original polypropylene and special composite raw material additives, and it is inflated using the gas injection method. This ensures that the product exhibits top-level performance in terms of impact resistance.
6	The shiny surface of the seat prevents the accumulation of dirt, making the cleaning process easier.
7	The seats are designed to resist breaking and disassembly by hooligans.
8	The burning process of the seat is delayed with FR (fire-resistant) additives, and this feature is certified with the UL 94 - V2 test report.
9	The steps used for assembly are drilled at two points, and after cleaning the holes, they are securely connected to the step with trifold screws through the doweling process. After assembly, the hole slots are covered with plastic caps to prevent water contact with the screws.
10	Thanks to the water channel, no liquid accumulates on the seat.

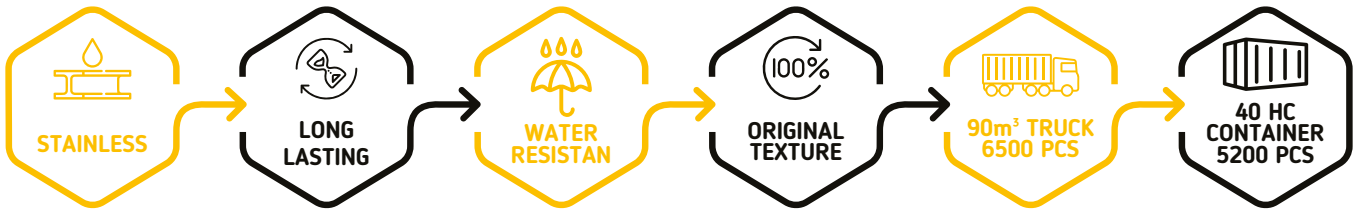

## PRODUCT IMAGES



## COLOURS

### Standard Ral Codes

RAL 3028	RAL 5002	RAL 6029
RAL 1018	RAL 9005	RAL 9010

## TECHNICAL DRAWING

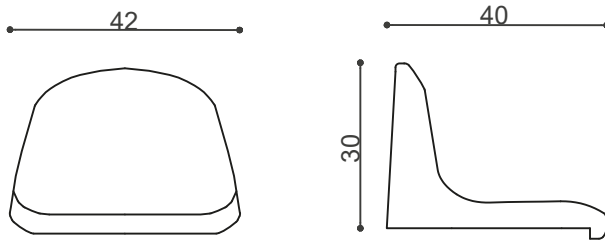

## PHOTOS FROM PRODUCTION



## INSTALLATION DRAWING

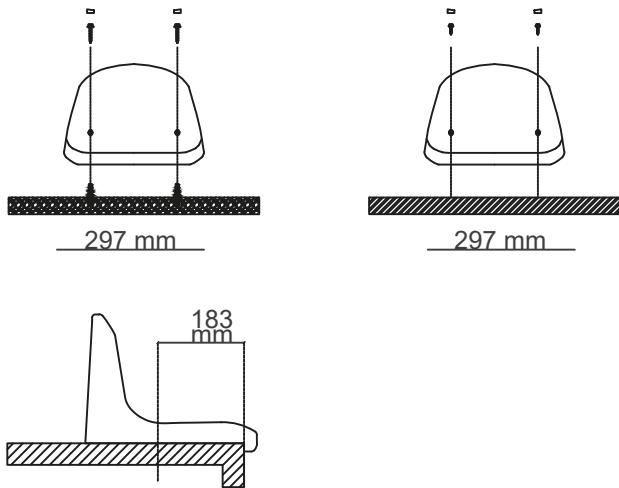

# BALANCE-Y

## APPLICATION AREAS

